



## Rico Ventex Isolation Valves

B-2.2

### INTRODUCTION

The Rico family of Ventex explosion barrier valves provides protection against the propagation of an explosion from one process vessel or area to another. They are extremely effective where the dust concentration is low in the explosive category 1 and 2 range. The standard valves require no external electrical detection or control and little maintenance.

### CONCEPT

The Rico valves use a suspended valve poppet. Under normal operation the air stream flows freely around the valve poppet. When an explosion occurs the valve poppet is thrown against the internal valve seat and locks into a closed position. Units are available in single and bi-directional versions. An additional version offers the benefit of assisted closing for applications with fast flame front propagation. The ESI-R model can be fitted as a check valve.

### BENEFITS

- √ No Detection or Controls Required
- √ Low Cost Maintenance
- √ Speedy Low Cost Reconditioning
- √ Fast Action Assisted Version Options
- √ Cost Effective Design

### DESCRIPTION

The Rico Ventex valves are used in applications where cost effective isolation, without sophisticated detection and control systems, are required. Their unique design allows them to be reconditioned, maintained and reused at exceptional low cost of operation. The valves basic construction uses a valve poppet suspended in

the flow area between one or two valve seats. An explosion force (Pressure Wave) moving ahead of the flame front hurls the poppet forward to the valve seat providing an airtight seal. The poppet once seated is locked in by a me-

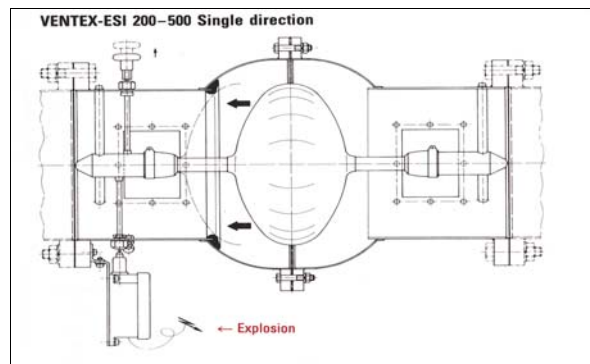

chanical shut-off device which retains the seal until manually reset. The three basic versions of the standard mechanical Ventex valve are available with a set pressure of 1.5 psi and a maximum pressure of 150 psi. The maximum operating temperature is 90° C. for Neoprene Seal units and 150° & 260° C. for optional two Silicone Seal units. The valves are designed for a maximum normal air velocity of 66 ft/sec (20 m/sec).<sup>1</sup> Optional configurations are available on request. Vapor use subject to Rico approval.



Ventex ESI-E

The **Ventex ESI-E** is a passive acting, single direction valve which is closed by the pressure wave of the explosion. They are applied in areas where the explosion can only come from one direction. Valves are available in sizes from 4 to 28 inches nominal diameter. The maximum airflow through the valve in the closing direction is 66 ft/sec.



**The Ventex ESI-D** is a passive acting dual direction valve which is closed by the pressure wave of the explosion. They are used in places where the explosion can occur in either direction. Valves are available in sizes from 4 to 20 inches nominal diameter.

**The Ventex ESI-R** check valve is a modified Ventex ESI-E. The valve poppet is normally held in a closed position by a spring. Normal process air flow opens the valve. When process flow stops or an explosion develops in the opposite direction to process flow, the valve closes automatically. The valve can only be used where the explosion direction and the process flow are in opposite directions.

The **NEW Ventex ESI-P** is an active acting single direction valve which is activated by a signal



from an explosion detector causing a gas generator to assist the valve in closing. It is used where the force of an explosion is not expected to generate enough pressure to shut the valve without assistance. The Ventex ESI-P's fast isolation speed and enhanced design make it extremely well suited for St3 class dusts of up to a KST of 500 bar-m/sec and pressures of up to 300 psi ( 20 bar ).

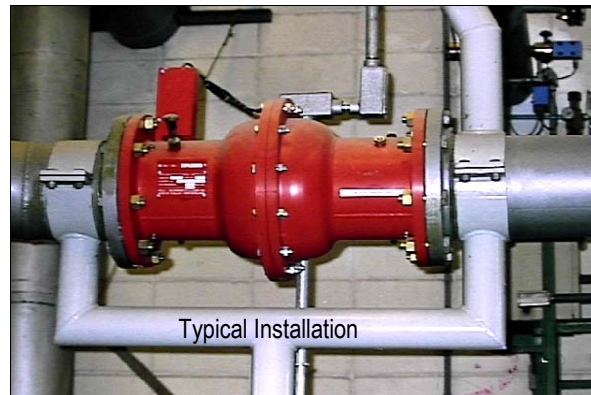

**ATEX Explosion Protection, L.P.**  
2629 Waverly Barn Road, Suite 124  
Davenport, FL 33897  
Ph: (863) 424-3000  
Fax: (863) 424-9797  
E-mail: [sales@atexus.com](mailto:sales@atexus.com)  
Web: [atexus.com](http://atexus.com)

Your local ATEX representative is: